

# Subsurface Barrier Verification with the SEAttrace™ Monitoring System

Subsurface Contaminants Focus Area and  
Characterization, Monitoring, and Sensor  
Technology Crosscutting Program



*Prepared for*  
U.S. Department of Energy  
Office of Environmental Management  
Office of Science and Technology  
September 2000



# Subsurface Barrier Verification with the SEAttrace™ Monitoring System

OST/TMS ID 308

Subsurface Contaminants Focus Area and  
Characterization, Monitoring, and Sensor  
Technology Crosscutting Program

*Demonstrated at*  
U.S. Department of Defense  
Dover Air Force Base  
Dover, Delaware  
and  
U.S. Department of Energy  
Brookhaven National Laboratories  
Upton, New York  
and  
U.S. Department of Defense  
Naval Air Station  
Brunswick, Maine



## ***Purpose of this document***

Innovative Technology Summary Reports are designed to provide potential users with the information they need to quickly determine whether a technology would apply to a particular environmental management problem. They are also designed for readers who may recommend that a technology be considered by prospective users.

Each report describes a technology, system, or process that has been developed and tested with funding from DOE's Office of Science and Technology (OST). A report presents the full range of problems that a technology, system, or process will address and its advantages to the DOE cleanup in terms of system performance, cost, and cleanup effectiveness. Most reports include comparisons to baseline technologies as well as other competing technologies. Information about commercial availability and technology readiness for implementation is also included. Innovative Technology Summary Reports are intended to provide summary information. References for more detailed information are provided in an appendix.

Efforts have been made to provide key data describing the performance, cost, and regulatory acceptance of the technology. If this information was not available at the time of publication, the omission is noted.

All published Innovative Technology Summary Reports are available on the OST Web site at <http://ost.em.doe.gov> under "Publications."

# TABLE OF CONTENTS

1. SUMMARY	page 1
2. TECHNOLOGY DESCRIPTION	page 5
3. PERFORMANCE	page 7
4. TECHNOLOGY APPLICABILITY AND ALTERNATIVES	page 15
5. COST	page 17
6. REGULATORY AND POLICY ISSUES	page 24
7. LESSONS LEARNED	page 25
<b>APPENDICES</b>	
A. REFERENCES	page 26

# SECTION 1 SUMMARY

## Technology Description

---

The use of subsurface containment technologies is a cost-effective remediation alternative being proposed and implemented at a wide variety of waste sites. So that these containment technologies may gain acceptance, the emplacement and performance of these barriers must be verified and monitored. Current techniques such as construction, quality assurance, and quality control during emplacement are insufficient. Traditional monitoring techniques rely on groundwater monitoring, and thus require the contamination of groundwater for indications of containment failure. The SEAttrace™ System uses a low-cost, early detection method to both verify subsurface containment emplacement and monitor long-term performance.

SEAttrace™ is an integrated monitoring system that can determine the size and location of leaks in subsurface barriers constructed above the water table. The system incorporates gaseous tracer injection, automated multipoint sampling, and real-time global optimization modeling to characterize the integrity of impermeable barriers.

Tracer gas is injected inside the contained volume of the barrier structure (Figure 1). An automated stand-alone system collects and analyzes soil gas samples for the presence and concentration of the tracer gas (Figure 2). A unique, on-board, global optimization modeling methodology analyzes tracer concentration histories to determine both the location and size of breaches in the barrier (Figure 3). The SEAttrace™ system also offers long-term monitoring of the barrier either by analyzing organic compounds contained by the barrier or by periodically injecting gaseous tracers.

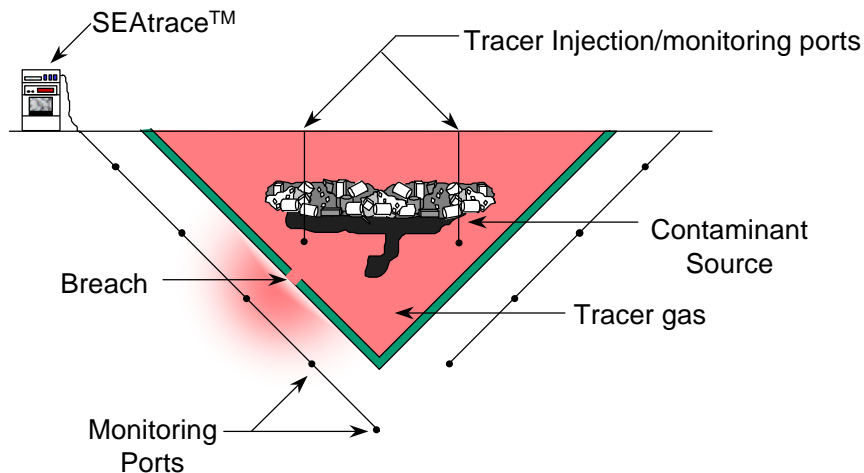

Figure 1. Schematic of the SEAttrace™ System



**Figure 2. Field Portable, Autonomous SEAtace™ System**



**Figure 3. On-Board SEAtace™ Scanning System Components Protected in Environmental Enclosure**

## Technology Status

---

Three field demonstrations have been conducted. In 1997 field demonstrations were conducted at two locations as part of a U. S. Department of Energy (DOE) Office of Science and Technology Program (OST): Verification and Monitoring Systems for Subsurface Barriers. The two 1997 locations included:

U.S. Department of Energy  
Dover Air Force Base  
Jet-Grouted Barrier Demonstration  
Dover, Delaware  
June through August 1997

U.S. Department of Energy  
Brookhaven National Laboratories  
Viscous Liquid Barrier Permeation Grouting  
Demonstration  
Upton, New York  
July through September 1997

Both 1997 demonstrations involved the close collaboration of several DOE laboratories and industry partners to create and evaluate subsurface barriers. Only the performance of the SEAttrace™ verification and monitoring system is described in this report. Installation and performance of the actual barrier systems as well as complementary monitoring technologies are reported elsewhere (Rumer and Mitchell, 1996; EPA, 1998; Dunn, Lowry, and Chipman, 1999).

In 1999 a field demonstration was conducted at the Naval Air Station (NAS), Brunswick, near Brunswick, Maine. Agencies present at the site included the U.S. Environmental Protection Agency (EPA), the Maine Department of Environmental Protection (MEDEP), the U.S. Navy (USN), and the DOE. The demonstration involved subsurface barrier validation of a section of a 2,300-linear foot, nominally 3-foot-thick soil-bentonite slurry wall emplaced around a landfill at the site. The U-shaped barrier prevents groundwater from flowing through the wastes contained within the landfill area.

The Viscous Liquid Barrier (VLB) demonstration was conducted at Brookhaven National Laboratory (BNL). Parties involved in the VLB demonstration included Sandia National Laboratories (SNL), Science and Engineering Associates, Inc. (SEA), Brookhaven National Laboratory (BNL), Lawrence Berkeley National Laboratory (LBNL), MSE Technology Applications (MSE), Lawrence Livermore National Laboratory (LLNL), and Westinghouse Savannah River Company (WSRC). The VLB was composed of colloidal silica (CS). The barrier was constructed as a V-shaped trough with three vertical ends and one angled wall. The interior dimensions of the barrier were approximately 30 feet (ft) by 36 ft by 3 ft thick, emplaced to a vertical depth approximately 29 ft below ground level (bgl) using permeation grouting methods.

The Jet-Grouted Barrier (JGB) demonstration was conducted at the Dover Air Force Base and included SNL, SEA, LBNL, LLNL, MSE, SRC, and E.I. DuPont de Nemours, Inc. (Dupont). The JGB was composed of high-pressure jetted, thin diaphragm walls. Barriers were constructed as boxes employing a natural clay layer as the confining bottom to the box. Box dimensions were approximately 8 ft by 24 ft and 15 to 35 ft deep.

The SEAttrace™ scanning system operated continuously at all of the demonstration sites. Between one and four scans were completed per day. The inversion code provided successful real-time leak analyses at both the Brunswick and the Brookhaven demonstrations. A first generation monitoring system was used at the Dover site. While this system automatically collected and stored concentration histories, the data had to be manually downloaded and sent electronically to the SEA office for analysis. Data analysis was done on site at Brookhaven and Brunswick.

The results of all the demonstrations were positive. SEAttrace™ detected flaws in all panels of the Jet Grouted and the Viscous Liquid Barrier (VLB). The known leaks (i.e., the leak test anomaly at Dover) and unintentional leaks were detected. The ability of the inversion code to locate flaws on the barrier was very good, typically locating the flaws within 1 to 2 ft from their true location. At Brunswick, the SEAttrace™ system showed the barrier to be free of defects, although the system clearly indicated the gap between the top of the barrier wall and the bottom of the cap.

## Contacts

---

### Technical

- Cecelia V. Williams, Technical Contact, Sandia National Laboratories, 505-844-5722, cvwilli@sandia.gov.
- Bill Lowry, Principal Investigator, Science and Engineering Associates, Inc., 505-424-6955, blowry@seabase.com.
- Sandi Dalvit Dunn, Science and Engineering Associates, Inc., 505-424-6955, sddunn@seabase.com.

### Management

- Mike Seratto, Westinghouse Savannah River Company, 803-725-5222, michael.serrato@srs.gov.
- Scott McMullin, DOE EM-50, DOE Office of Science and Technology Program Manager, 803-725-9596, scott.mcmullin@srs.gov.
- Edward Rizkalla, CMST HQ Program Manager, Office of Science and Technology, U.S. Department of Energy-Headquarters, 202-586-9112, edward.rizkalla@em.doe.gov.
- Joseph Ginanni, Manager, National Programs, U.S. Department of Energy Nevada Operations Office, 702-295-0209, ginanni@nv.doe.gov.
- John Jones, CMST Field Technical Manager, U.S. Department of Energy, 702-295-0532, jonesjb@nv.doe.gov.

### Other

All published Innovative Technology Summary Reports are available on the Office of Science and Technology (OST) web site at <http://ost.em.doe.gov> under "Publications." The Technology Management System (TMS), also available through the OST web site, provides information about OST programs, technologies, and problems. The OST/TMS Reference Number for Subsurface Barrier Validation is 308.



## SECTION 2 TECHNOLOGY DESCRIPTION

### Overall Process Schematic

---

The SEAttrace™ Verification and Monitoring System detects leaks in a subsurface barrier non-destructively for post-emplacement verification and monitoring. A tracer gas is injected into the contained area formed by the barrier and is allowed to diffuse within the barrier volume to a target concentration. If a breach is present, the tracer gas diffuses through the breach into the surrounding medium. The SEAttrace™ monitoring system detects the tracer gas and an inverse optimization code analyzes the data (Figure 4).

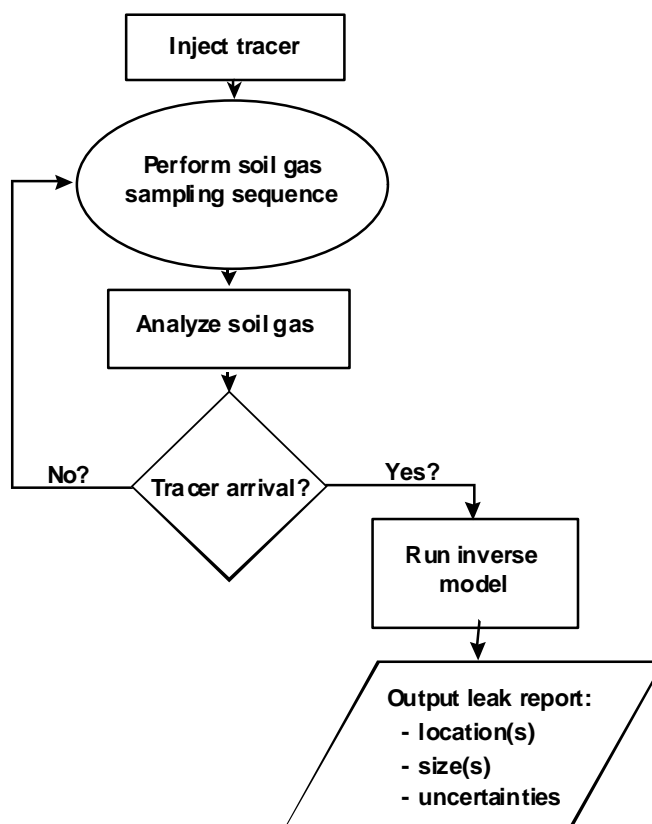

**Figure 4. SEAttrace™ Process Schematic**

The SEAttrace™ Verification and Monitoring System is based on the simple and predictable transport process of binary gaseous diffusion in porous media. Diffusion is an attractive process to utilize for leak detection because the tracer concentration histories measured at locations distant from the source are highly sensitive to both the size of the breach and the distance from the leak source. The SEAttrace™ System is made up of two distinct, integrated functional components: a monitoring system and an optimization code.

As shown on Figure 1, multiple vapor sample points are located outside the barrier as well as one or more injection and sample ports inside the barrier. These ports are connected to a stand-alone data acquisition and analysis system. A tracer gas (typically sulfur hexafluoride) is injected in to the barrier, creating a concentrated source volume of the tracer gas within the barrier. If the barrier has a breach, the

tracer gas will diffuse into the surrounding medium and the exterior sample ports will measure the amount of tracer gas in the soil over time.

Once tracer gas concentration history data have been collected, it is analyzed to determine the location and size of the leak(s). To overcome the difficulties of standard diffusion models, a global optimization technique was developed to effectively search multi-dimensional "space" to simultaneously find the best-fit solution based on all of the input parameters. The code iterates to find a best-fit solution for the location and size of the breach given the input parameters. In the optimization code, the concentration histories and location of the sample ports are assumed to be known. Properties of the medium, the source concentration and size and location of the breach(es) are treated as unknowns. The general methodology of this approach rigorously searches for a set of parameters that will best characterize the leak. The method requires a diffusion model that calculates concentration histories at the sample ports from the multi-parameter "space." These calculated concentrations are compared with the measured concentrations using an objective function. The objective function is defined as the sum of the squares of the differences between the predicted and measured tracer concentrations. A stochastic method, Simulated Annealing, is then employed to minimize the objective function, thus finding a best fit to the data given a range of defined parameters. The technique selects points from the given input ranges for each parameter at random. Using these values, the objective function is evaluated. The process is repeated; the two values for the objective functions are then compared, and the code chooses which is more accurate. This point is "remembered" and the process repeated with a new set of parameter values. The parameter values are chosen using a probability distribution that relies on the objective function of previous points in a complex way. The accuracy of the results depends on how well the chosen leakage model matches reality, and on the number and ranges of the unknown input parameters.

Presently, the code developed to analyze the measured data is limited to a single, one-dimensional spherical diffusion model. The model is further restricted by assuming that a constant source concentration is maintained inside the barrier, the barrier is planar, and that the medium outside the barrier is homogenous (i.e., that the diffusivity of the tracer gas through the soil pores is constant). While this diffusion model is simplistic, as a first-order approximation, it is realistic. If the area of the barrier wall is much greater than the area of the leak, at some distance from the leak the gas will approach spherical diffusion regardless of the true geometry of the leak. Additionally, the barrier wall will act as a flat, no-flow boundary and the medium through which the tracer gas is diffusing can be assumed to be semi-infinite. A more detailed description of this model and its limitations may be found in the topical report by SEA (Dunn, Lowry, and Chipman, 1999, Appendix C).

## **System Operation**

---

Since SEAt<sup>TM</sup> is a solar-powered system, no site power is required. During extended cloudy periods, a portable generator, which automatically switches on, recharges system batteries when the batteries are low. SEAt<sup>TM</sup> is a trailer-mounted unit, requiring an area less than 40 square ft. The system is equipped with its own thermal control and remote access and transfer data capabilities via cellular modem.

## SECTION 3 PERFORMANCE

### Demonstration Plan

---

The SEAttrace™ System was demonstrated at three locations: Dover Air Force Base (DAFB), Brookhaven National Laboratories (BNL), and Brunswick Naval Air Station (BNAS). DAFB is in Dover, Delaware, in the Coastal Plain physiographic region. Since the beginning of operations in 1941, materials typically used at many military bases have impacted the environment at DAFB. DAFB is a U.S. Environmental Protection Agency (EPA) National Priorities List site that is being remediated pursuant to the National Contingency Plan. A basewide remedial investigation has been conducted for the site. The National Test Site for testing and evaluating innovative environmental technologies is located at DAFB.

BNL is in Upton, Long Island, New York, near the geographical center of Suffolk County. The BNL facility occupies 5,265 acres of land, 75% of which is wooded. The terrain is gently rolling with elevations ranging between 13.4 and 36.6 meters above mean sea level. The property lies on the western rim of the shallow Peconic River watershed, with a principal tributary of the river in the north and west sections of BNL. BNL is a multi-disciplinary scientific research center owned by the U.S. Department of Energy (DOE). In 1989 BNL was added to the EPA priority list. The specific site chosen for the demonstration is between the former landfill and the Glass Holes area.

BNAS is south of the Androscoggin River between Brunswick and Bath, Maine. The topography at the site is characterized by low undulating hills with deeply incised brooks. The ground-surface elevation ranges between mean sea level to over 110 ft.

Major objectives of the demonstrations were to:

- Evaluate the performance of the selected grouting methods to emplace a continuous barrier.
- Evaluate the ability of the barrier to form a continuous barrier of low permeability.
- Verify and monitor the emplacement and performance of the barrier using conventional and novel methods and approaches.
- Evaluate the performance of the verification and monitoring methods and approaches.

### Treatment Performance

---

The test results indicated that the ability of the inversion code to locate flaws in the barrier is good, locating a test anomaly and two engineered flaws within 1 to 2 feet from their actual locations in space. A summary of the results of the inversion operation on the test panels at Dover, Brookhaven, and Brunswick test sites is presented below.

#### Dover AFB Test Site

Schematics of the DAFB jet-grouted test boxes are shown on Figures 5 and 6. These test boxes with discrete cells were created using jet-grouting techniques and tested using a variety of verification and monitoring methods, including the SEAttrace™ System. Installation and operation of the SEAttrace™ System is shown on Figure 7. Results of the SEAttrace™ tests are summarized below.

- A leak test anomaly chamber was constructed near the Shallow Passive Box using a buried container with a three-inch diameter gate valve located at the 5.5-ft depth. The inversion code located this leak within 0.9-ft, and indicated the leak diameter of 3 inches accurately. Figures 7 and 8 show the leak test anomaly chamber and the SEAttrace™ detection output from this test.

- The SEAttrace™ System located three discrete flaws in the west test cell (cell SA-C1) of the Shallow Active Box: (1) a long, distributed flaw running along the bottom of the north panel where the panel intersects the water table, (2) a discrete leak located on the west panel in its lower central area (at 5.9-ft depth), and (3) a flaw on the south panel at the 7.6-ft depth on the joint between the south and west panels. In the initial tests of the Deep Active Box, three leaks were located in the south test cell (cell DA-C1): (1) a leak was located at 11.9-ft depth where the west panel joins the panel to the north, (2) a shallow leak at 7.3-ft depth, located on the seam of the south panel and west panel (0.1 inch diameter), and (3) a joint flaw (0.1-inch diameter) at 11.0-ft depth just south of the panel's northern most vapor monitoring port. After completion of the initial Deep Active Box testing, an engineered leak was drilled at a shallow angle into the south panel using a 12-inch diameter auger. Tracer gas concentrations were increased inside the cell after the engineered flaw was formed. As shown on Figure 9, inversion of the resulting data centered the flaw at the 11.6-ft depth, indicating a 4.5-inch diameter hole on the right center of the south panel, which was the anticipated target.

The test results of the flaws in the Shallow Active Box test cell corroborate the results of the hydraulic, saturated tracer, and electrical resistance tomography field tests (conducted as part of the overall, larger barrier demonstration project). Each of these techniques showed detectable flaws in the area of the north panel of the SA-C1 test cell, and the barrier construction records indicate an operational event which may have caused an incomplete joining of sections. Hydraulic tests in the Deep Active Box test cell DA-C3 showed extensive flaws in the barrier, which would be consistent with the flaws detected in DA-C1 with the tracer system. It should be noted that the SEAttrace™ system data on size and position of leaks was available soon (less than a day) after the tracer gas had diffused out the flaws. The hydraulic and saturated tracer tests involved injecting fluid into the barrier, which is not an option at a hazardous waste site. Also, these two techniques do not give information on the size and location of flaws.

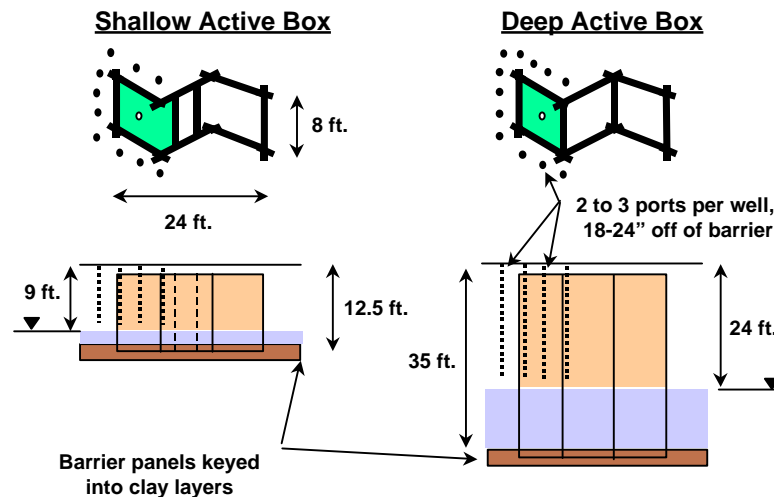

**Figure 5. Schematic of Thin Wall Jet-Grouted Diaphragm Barrier Test Cells at the Department of Defense Dover Air Force Base Groundwater Remediation Field Laboratory, Delaware**

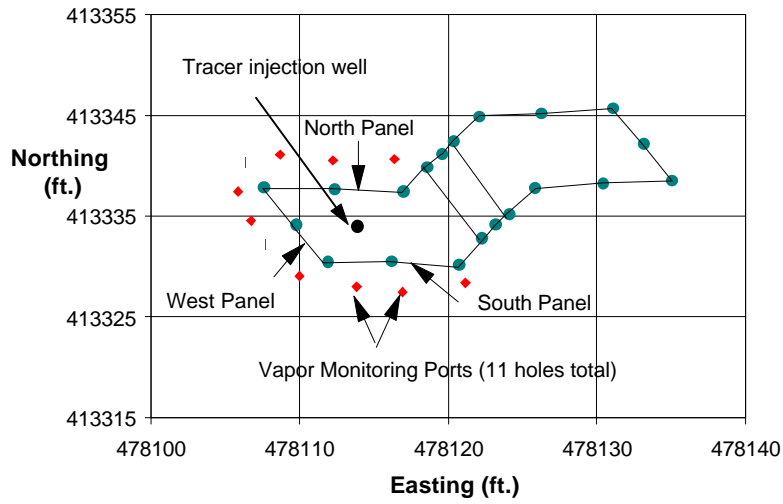

Figure 6. Shallow Active Box plan view and vapor sampling port (squares) configuration.

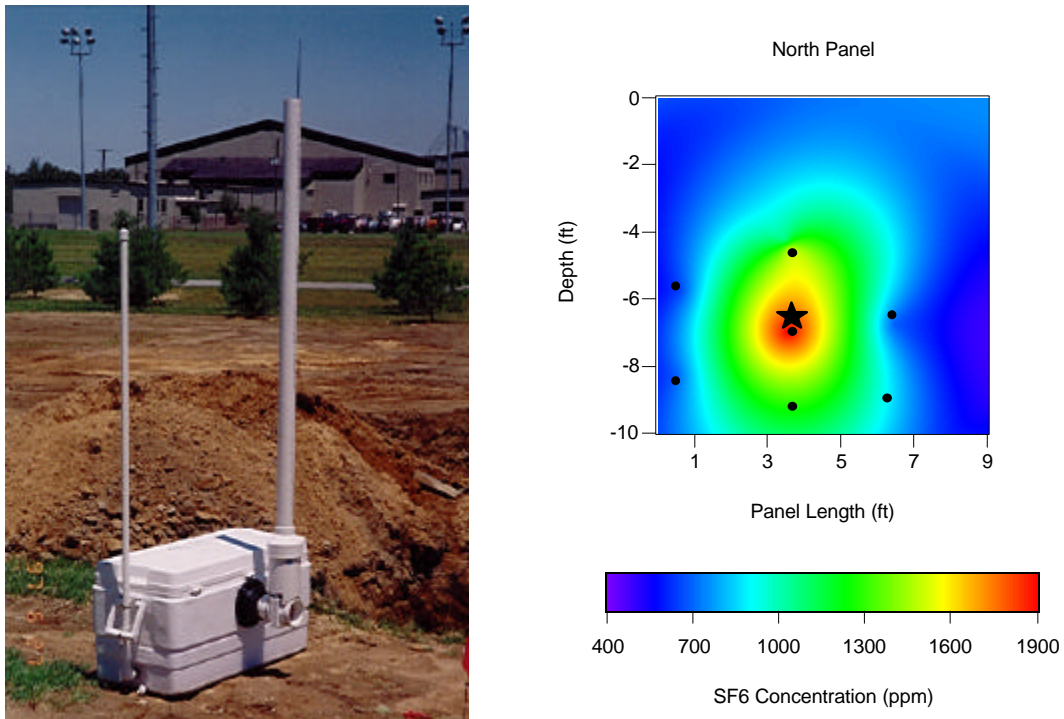
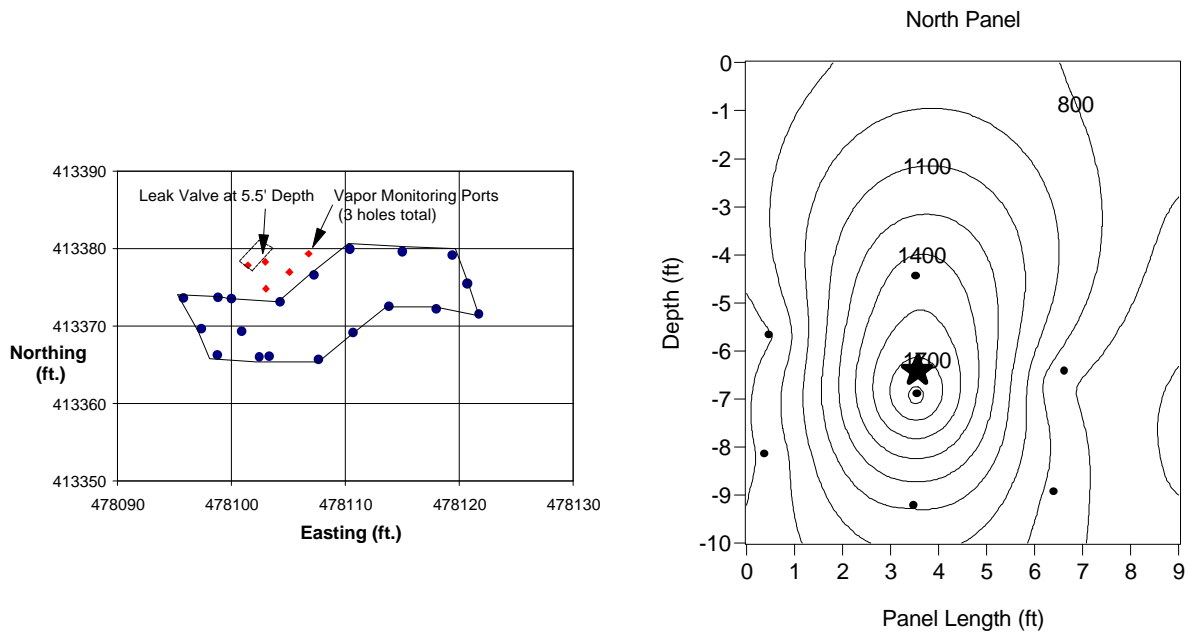
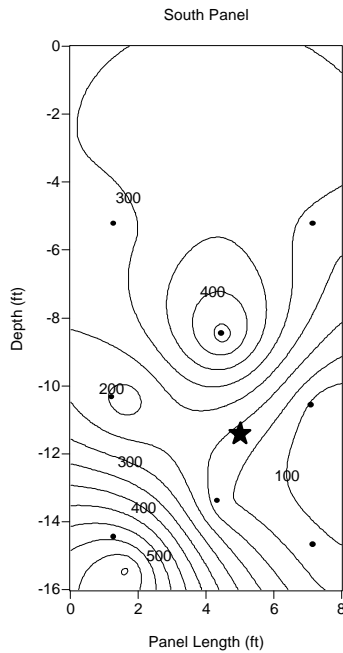

Figure 7. The Leak Test Anomaly Chamber buried at the Dover AFB site is shown on the Left. The test chamber was used to simulate a subsurface leak using a gate valve to release tracer gas. The test leak was detected using the SEAtace™ System as shown on the right.



**Figure 8. Leak anomaly configuration (adjacent to shallow passive test box) and concentration data showing inferred leak location (star) adjacent to vertical panel section. Black circles on schematic to right denote vapor sampling port locations.**



**Figure 9. Tracer concentration profiles and inferred leak location (star) created by the 12-inch hole that was drilled horizontally through the south panel of the Deep Active Box. Vapor monitoring ports are indicated by solid black circles.**

## Brookhaven National Laboratory Test Site

A schematic showing the Viscous Liquid Barrier (VLB) and tracer-monitoring array in Brookhaven, NY is shown in Figure 10. A photograph of the full-scale remotely operated SEAttrace™ system on site is shown in Figure 11. A representative profile of a leak in the east panel is shown in Figure 12. Combining contour plots, simple modeling, and the information calculated by the SEAttrace™ System, the integrity of the VLB barrier can be summarized by panel as:

- Vertical side wall: There are two clearly defined breaches in this panel. Both are in the top half of the panel, one close to the north end panel and the other to the south end panel. The breach closest to the south end panel is the larger of the two.
- Slant side wall: There are two large leaks very close to each other (probably within a meter) on the north side and approximately midway down the panel. There is at least one smaller leak on the southern side and closer to the top of the panel.
- Southern end wall: This panel appears to have numerous breaches. There are two areas along the wall where the surface seal did not meet the top of the panel, indicating that the panel probably does not extend to within 3 feet of the surface. There is a clearly defined breach near the bottom of the wall. There also appears to be a breach near the intersection of the panels with the vertical sidewall, approximately half-way down the panel.
- Northern end wall: This panel showed the lowest measured concentrations with time. The main leak found on this panel was near the top of the wall, most likely caused by a column not extending to within 3 feet of the surface. The only other leak found by the inversion code is near the intersection of this panel and the vertical sidewall, about halfway down the panel.

The SEAttrace™ system performed autonomously on-site for several weeks. However, due to scheduling constraints, long-term monitoring of this barrier was not performed using the SEAttrace™ system.

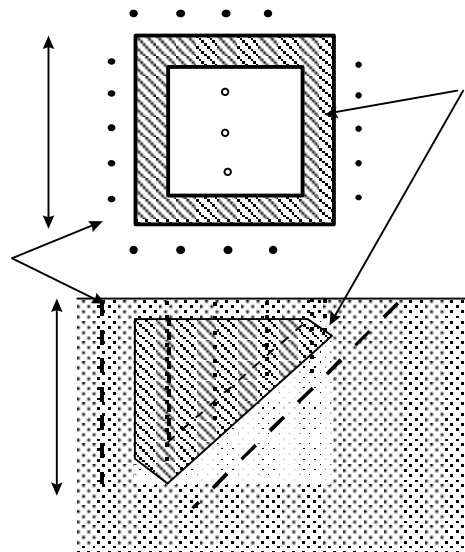

Figure 10. Schematic of the BNL barrier and the SEAttrace™ monitoring array configuration at the Viscous Liquid Barrier (VLB) test site in Brookhaven, NY. Top view of Barrier and side view of slant side wall.



Figure 11. SEAttrace™ System remotely operated on site at the Viscous Liquid Barrier (VLB) test site in Brookhaven, NY (background). In the foreground, completion of the vapor sampling point installation can be seen.

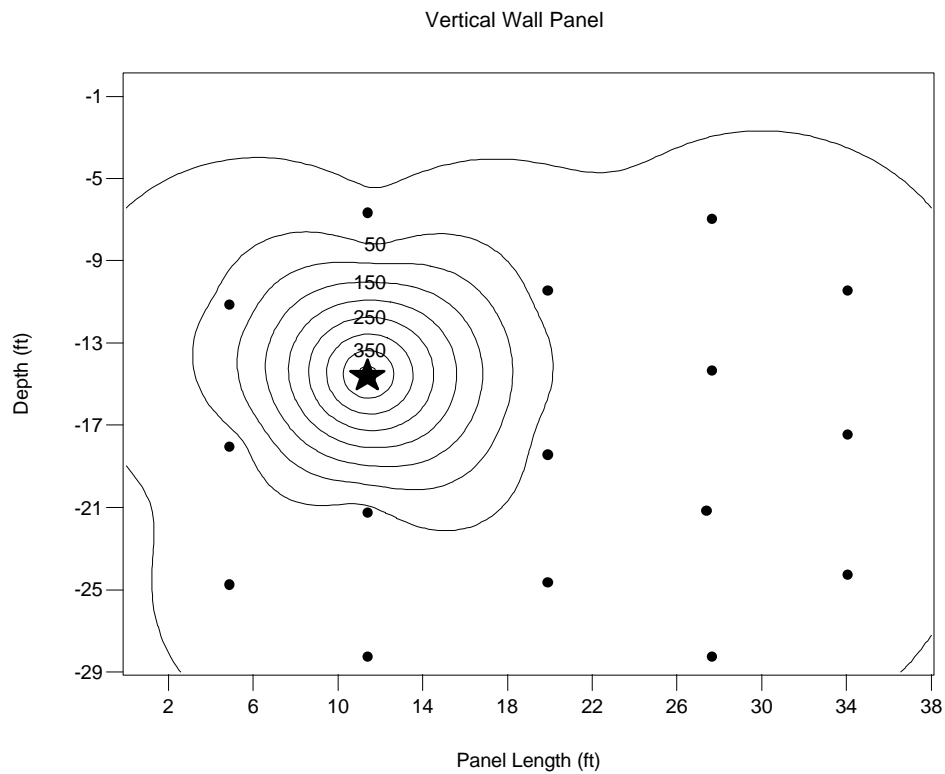

Figure 12. Tracer concentration contours and leak location determined by SEAttrace™ inversion code at Viscous Liquid Barrier (VLB) test site.



## Brunswick Naval Air Station Test Site

Injection ports were spaced inside the BNAS barrier to provide a constant tracer source concentration along the portion of the wall used in the demonstration using the fewest number of ports possible. Spacing from port to port and from the port to the walls was guided by numeric modeling with T2VOC. Seven injection ports were needed. The ports were spaced 15 feet apart from one another and were installed to a depth of 11 feet below the top of the barrier wall (14 feet below ground surface). The ports were located 9 feet from the barrier wall. Figure 13 schematically depicts the area of influence of each injection port.

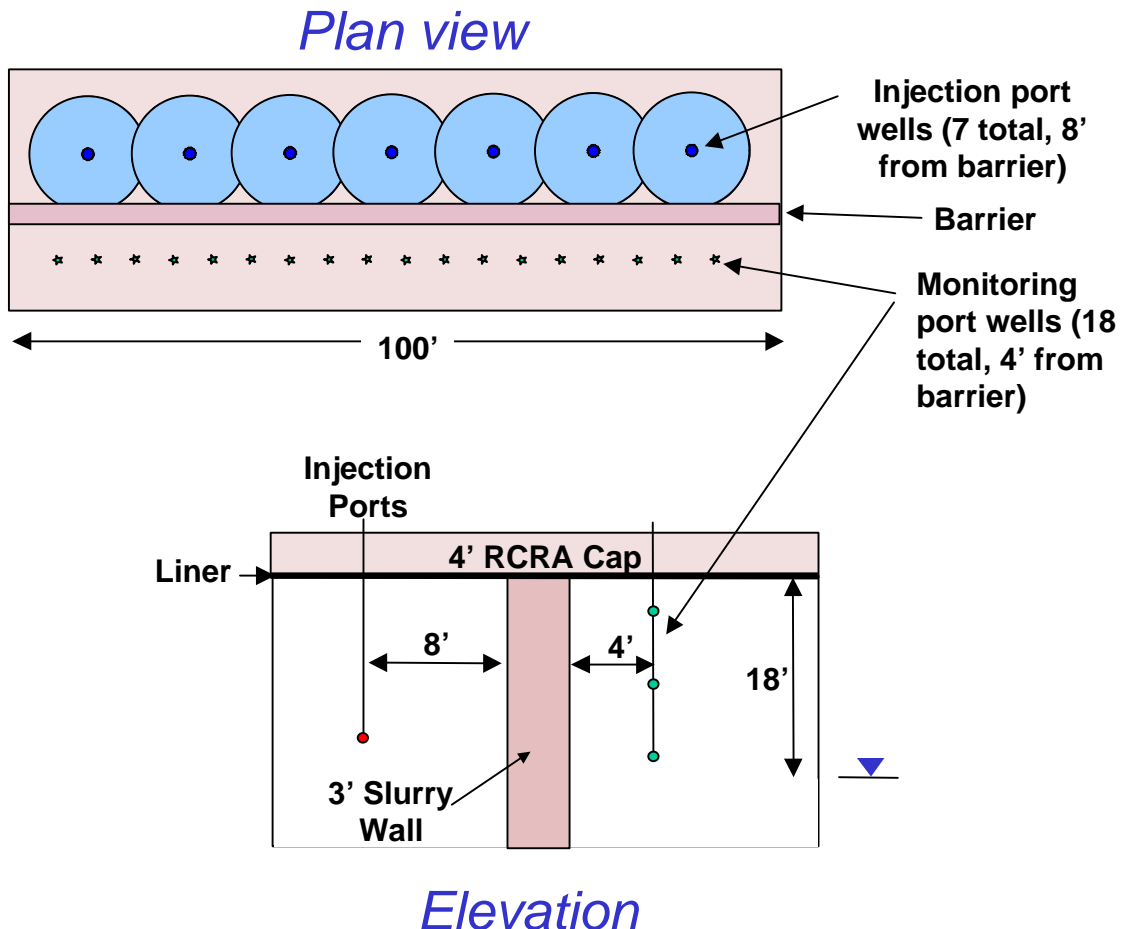

Figure 13. Plan and elevation views of the SEAttrace™ installation at the demonstration site.

The tracer gas injection scheme for the SEAttrace™ system is designed to create a uniform concentration of tracer along the barrier wall itself rather than within the volume of the enclosed soil. Injection occurs in slow, controlled, staged steps. Initial injections at one or more low concentrations allows detection of relatively large flaws, if they exist, without the possibility of flooding the medium with such high concentrations of the tracer that the maximum detection limit of the gas analyzer is exceeded. Subsequent testing at higher tracer concentrations allows the system to search for successively smaller leaks. While the typical starting concentration is 2,500 ppm, calculations showed that the overall distance between the injection and the monitoring ports for this demonstration (15 feet) would preclude any but extremely large leaks to be seen within the allotted time. Additionally, hydraulic testing of the barrier has shown the areas of the barrier below the water table to be water tight, indicating that general construction

of the barrier was sound. Thus the starting concentration was increased to 20,000 ppm. After 10 days the source concentration was raised to the target demonstration concentration of 80,000 ppm.

No breaches were detected in the barrier during the test. However, there was a gap between the top of the slurry wall and the impermeable liner in the barrier cap. Tracer was able to travel through this gap and “spill” over the barrier. Exterior monitoring ports were able to detect the tracer as it traveled from the top of the barrier down to the water table.

In addition to measuring the tracer gas, carbon dioxide and water vapor histories were recorded. Carbon dioxide concentrations were very high, between 70,000 and 130,000 ppm. Because the barrier cap extended well beyond the slurry wall, CO<sub>2</sub> generated in the soil could not diffuse to the atmosphere. The gas was measured as a check of the scanning system - the gas analyzer is functioning properly if the values remain consistent with time. This is also an indication that there are no leaks in the scanning system plumbing and verifies the integrity of the tubing. After ports are installed, tubing can be damaged as a result of exposure to ultraviolet light or rodent intrusion. The amount of CO<sub>2</sub> in the atmosphere is low (600 - 800 ppm) at the site. If a tube had been damaged, the measured concentration of CO<sub>2</sub> at the port would have dropped significantly and remained low. This was not seen during the test.

A calibration gas was measured throughout most of the demonstration. The calibration gas is an indicator of how well the scanning system is operating. It can detect leaks in the internal plumbing of the system (by indicating a sample dilution from the known concentration) or failure of the gas analyzer (by indicating erratic or inconsistent concentrations). The calibration gas is added to a large Tedlar™ sample bag that is connected to one of the ports on the scanning system. The bag must be refilled every 5 to 7 days. No indication of problems was seen in the data.

An engineered leak was installed and tested during the course of the demonstration. The engineered leak was located approximately 50 feet from the slurry wall and was a test of the system, not of the wall itself. A large pipe (8-inch diameter) was buried so that a valve at the bottom of the pipe was 6 feet below ground surface. The pipe acted as the source volume for the tracer gas. A 1.5-inch diameter gate valve formed the leak. The system was able to locate the leak to within 3.3 feet (1 m) of its true position.

## SECTION 4 TECHNOLOGY APPLICABILITY AND ALTERNATIVES

### Technology Applicability

---

The problems targeted for these demonstrations included subsurface barrier verification and validation and monitoring of two barrier emplacement techniques and materials. Other subsurface barriers may include slurry trench cut-off walls, plastic or diaphragm cut-off walls, thin panel cut-off walls, column barriers, and naturally occurring low-permeability geologic formations. Parameters for consideration of other application of this technology include type of barrier, shape of barrier, construction quality control, and on-site geologic characteristics.

Development challenges for this technology include accurate location of sample points in the subsurface, relating results to regulatory and performance requirements, and tracer gas sensor detection limits and dynamic range.

### Competing Technologies

---

Current practices for the verification and monitoring of subsurface barriers include:

- Construction Quality Assurance: Grout balance, surface survey, and materials quality assurance. These methods provide no guarantee of integrity.
- Geophysics: Radar, acoustics, electromagnetics. These methods have questionable capabilities in detecting small leaks.
- Excavation: Unlikely for contaminated sites.
- Hydraulic Testing: Not suitable for contaminated sites as mobilization of the waste might occur.

Benefits of gaseous tracers for subsurface barrier verification and monitoring include:

- Rapid results.
- Conservative results.
- Relatively insensitive to heterogeneous media.
- Discrete leak characterization.
- Small leak detection.
- Discriminates multiple leaks.

A summary of current practices for the verification and monitoring of subsurface barriers used in the overall barrier demonstration project is given in Table 1.

<b>Table 1. Barrier Verification and Monitoring Project Technology Matrix.</b>		
<b>Verification and Monitoring Performance Area</b>	<b>Technology</b>	<b>Capability</b>
<b><i>Aerial Extent</i></b>	Ground Penetrating Radar (GPR)	17-meter penetration, vadose and saturated zones, sandy soils with limited clay content
	Electromagnetic Logging	Depth not a significant constraint, vadose and saturated zones, results not limited to geologic media
	Seismic Cross-Bore Hole Tomography	Works well in clay units, saturated zone, below the water table, results were inconclusive of barrier location
	Electrical Resistivity Tomography (ERT)	Depth not a significant constraint, vadose and saturated zones, results not limited by most geologic media
<b><i>Hydraulic Performance</i></b>	<i>In Situ</i> Permeameter	Point hydraulic performance - vadose zone
	Hydrogeologic Flood Tests	Bulk hydraulic performance - vadose zone
	Hydrogeologic Extraction Tests	Bulk hydraulic performance - saturated zone
	<i>In Situ</i> Moisture Sensors	Soil moisture movement through the media - vadose zone
<b><i>Continuity and Integrity</i></b>	General Vapor Tracer Techniques	Barrier discontinuity and leak location - vadose zone
	SEAtace™ Vapor Tracer Technique	Closed or open surface system, vadose zone, real-time, autonomous, automated, simple detector
	PFT Multiple Vapor Tracer Technique	Open surface system, vadose and saturated zones, manual, complicated detector
	Electrical Resistivity Tomography (ERT)	Barrier discontinuity - can be applied during barrier emplacement
	HydroLab Water Analyzer	Groundwater physical and chemical changes adjacent to the barrier – temperature, pH, conductivity, etc. - Saturated Zone

### **Patents/Commercialization/Sponsor**

---

Patent pending.

## SECTION 5 COST

### Introduction

Because the SEAttrace™ methodology offers assessment capability where none previously existed, potential costs based on the two 1997 demonstrations were estimated. The system cost per square foot varies with the size of the barrier to be assessed. Table 2 displays a cost breakdown for three potential SEAttrace™ installations. The cost of using the system decreases dramatically to just a fraction of barrier installation cost as the size of the installed barrier approaches that of a realistic hazardous waste site application.

<b>Table 2. Usage Cost Summary for Potential Installations.</b>			
<b>Scale of Barriers:</b>	<b>Test Scale</b>	<b>Small</b>	<b>Medium</b>
Depth	3 m	10 m	30 m
Length	6 m	20 m	30 m
Approximate Square Footage	840 ft <sup>2</sup>	7,500 ft <sup>2</sup>	42,000 ft <sup>2</sup>
Vapor point installation method:	Manual	Geoprobe™	ResonantSonic™
Installation cost			
-Equipment	\$5 K (purchase)	\$5 K (rental)	\$20 K (mobilization) \$35 K (drilling time)
-Expendables	\$1 K	\$2 K	\$5 K
-Labor	\$10 K	\$15 K	(included)
Total Installation Cost:	\$16 K	\$22 K	\$60 K
Mobilization, travel, tubing hookup, & monitor system checkout	\$15 K	\$20 K	\$25 K
Monitoring System	\$50 K	\$60 K	\$75 K
Tracer Gas	\$8 K	\$12 K	\$25 K
Design, Tech. Support, and Data Reduction	\$40 K	\$50 K	\$130 K
<b>Total Cost</b>	<b>\$129 K</b>	<b>\$164 K</b>	<b>\$315 K</b>
<b>Unit Cost Per Barrier Wall Area</b>	<b>\$150/Ft<sup>2</sup></b>	<b>\$22/Ft<sup>2</sup></b>	<b>\$7.50/Ft<sup>2</sup></b>

A detailed cost analysis was performed based on the 1999 demonstration at Brunswick that is detailed in the remainder of this section.

### Methodology

Expenditures were itemized as capital and operating costs. Capital costs refer to those expenditures incurred during the equipment mobilization, setup, and commissioning. Operating costs refer to costs incurred during the testing and operational phase of the project. Items such as drilling, well installation, monitoring equipment, accessory equipment, and installation labor are considered to be capital expenditures. Operating expenditures include tracer gas, power, labor, and maintenance.

## Cost Analysis

---

### Capital Costs

A grid system of sampling ports was set up to test the barrier. The grid for the BNAS demonstration was defined with 64 sampling points. An average system spaces the wells 5 to 15 feet apart with sampling ports spaced down the wells at intervals equal to or less than the horizontal spacing. At the BNAS demonstration there were a total of 18 wells each having 3 sampling points per well, totaling 54 sampling points.

Well installation costs depend on the well depth and soil characteristics. The deeper the well or the harder the soil, the more expensive it is to drill. In the case of the BNAS demonstration, a Geoprobe™ was used because wells were emplaced at a shallow depth (25 ft) and in sandy soil. The Geoprobe™ operates by pushing a steel rod through the soil using a hydraulic mechanism. The Geoprobe™ cost \$1,200 per day, which includes the crew and the equipment rental.

Vapor ports, tubing, and backfill were installed in the drilled holes. The cost for these materials was 1.7 times the drilling costs. (This figure results from a scaling up of data collected at a small barrier; SEA used that data to arrive at average costs for large, medium, and small barriers.) Labor was also included in the well-installation cost. Oversight and coordinate calculations for drilling require an engineer. Installation of the vapor ports, tubing, and backfill mix requires two technicians. Overall supervision requires one senior engineer. Rates were supplied by SEA as stated below.

- Technician: \$450/day
- Engineer: \$600/day
- Senior Engineer: \$625/day

Based on experience by SEA at Brunswick, it is assumed that a Geoprobe™ can drill five wells per day. For wells 30 to 50 ft deep, it was assumed that two wells per day could be drilled. For wells deeper than 50 ft, 0.5 wells could be drilled per day. Costs for wells that are deeper than 30 ft but less than 50 ft increased from \$1,200 per day to \$1,800 per day. Wells greater than 50 ft deep would cost \$3,000 per day.

The monitoring system equipment costs were estimated by SEA to be \$100,000 with an initial mobilization charge of \$6,000. It would seem reasonable that the unit would be rented because the equipment is being used for verification only. From SEA cost data, it is estimated that a rental charge would be \$2,000 per month.

Table 3 summarizes capital costs for the SEAtace™ process for barrier verification that is 150 feet long by 25 feet deep.

**Table 3. Capital Cost for the SEAttrace™ Process for a Barrier 150 Feet Long by 25 Feet Deep.**

<b>Capital Cost/Item</b>	<b>Cost (\$)</b>
Drilling	4,800
Expendables	8,112
Labor	8,500
Mobilization	6,000
<b>Total</b>	<b>27,412</b>

**Operating Costs**

Operating costs include the equipment rental, setup, testing, and data analysis. Rental of the SEAttrace™ system would be \$2,000 per month. SEA derived this cost by adding a 20 percent maintenance charge to the original equipment cost (\$100,000) and amortizing it over 5 years, which would total \$120,000 divided by 60 months or \$2,000 per month.

System setup is a significant cost. For every grid, the system must be moved, connected, recalibrated, and recoded. The bulk of the cost was from the labor necessary to recode the system. By recoding the system, the technician reprograms the system for a different set of coordinates. The system must be recalibrated to discriminate between background tracer gas and injected tracer gas. It was estimated by SEA and confirmed with field demonstrations cost data that each grid cost \$24,750 to accomplish the system setup.

Each test requires tracer gas and labor to inject the tracer. It is assumed that 6 days per grid are needed to operate and maintain the system; this work can be accomplished using a technician. Tracer gas costs vary from \$250 to \$1,000 per compressed bottle due to transportation costs and a limited number of suppliers. Each bottle contains approximately 300 cubic feet of gas, and one bottle of tracer gas is required per grid test.

Once data are collected by the SEAttrace™ system, the inversion code is run to analyze the samples and locate the concentrations. This data are then relayed to SEA through remote cellular capabilities, or in the case of the BNAS demonstration, a person will download the data once a week and send it to SEA (BNAS would not allow a cellular phone at the site).

Once received by SEA, an engineer will check the automatic data analysis using contour plots and independent inversion analysis, and review recorded operating data to assure the system is operating within specification. It was assumed it would take two hours every day for this analysis. The engineering rate as stated by SEA would be \$600 per day. Table 4 summarizes the operating costs of the BNAS demonstration for a barrier approximately 150 feet long by 25 feet deep.

**Table 4. Operating Costs for the SEAttrace™ Process.**

<b>Operating Cost/Item</b>	<b>Cost (\$/Month)</b>
Equipment rental	2,000
Equipment/test setup	49,500
Testing	7,400
Data analysis	6,600
<b>Total</b>	<b>65,500</b>

Other operating costs not included in the demonstration costs are travel, technical support, and reporting. These costs vary according to site characteristics and needs; consequently, these costs are not included in the core cost of the demonstration even though travel costs can be as much as 15 percent of the total demonstration costs.

## **Cost Conclusions**

---

### **Baseline Costs**

Since no subsurface barrier verification technology is in common use, no baseline technology exists per se. However, an alternative barrier verification technology under development by Brookhaven National Laboratory (Heiser, 1994) was evaluated for cost comparison purposes. The alternative process is similar to the SEAttrace™ system except more labor is required to manually sample each port daily, and laboratory analysis is required for each sample.

Capital costs include well installation and sampling equipment. It is assumed that well installation costs were equal to those of the SEAttrace™ process. Two vacuum pumps and approximately 500 Tedlar™ air sample bags would need to be purchased. It is assumed the bags could be purged and reused after laboratory analysis. The Cole Parmer™ catalogue quotes these costs as:

- Tedlar™ bags, \$62 each
- Vacuum pumps, \$200 each

These items were amortized over the equipment life and accounted for as a function of the project duration. Table 5 summarizes the capital costs for the alternative process.



**Table 5. Capital Costs for the Alternative Process.**

<b>Capital Cost/Item</b>	<b>Cost (\$)</b>
Drilling	4,800
Expendables	8,112
Labor	8,500
Testing equipment	872
Mobilization	6,000
<b>Total</b>	<b>28,284</b>

Baseline process operating costs are similar to those of the SEAttrace™ system, although more labor is needed to manually take samples every day. From information supplied by SEA, it is assumed that one technician would require eight hours to sample all 64 points of the grid. Samples must be taken daily for the test period. A typical test period is 21 days. Laboratory costs are also incurred in the alternative process.

The MSE-HKM laboratory, when contacted for an estimate to analyze sulfur hexafluoride, stated that a rented gas chromatography unit and a full-time technician would cost approximately \$27 per sample.

Data analysis costs would be higher than the SEAttrace™ system due to the increased programming that needs to be performed for finite elemental analysis. Costs were taken from an MSE draft report entitled *Cost Analysis for Geophysical Verification of a Subsurface Barrier*. This report suggests that it would take one engineer 40 hours to program the analysis software and 5 hours per well hole to analyze the data. For 16 wells, it would take 120 hours per grid. Table 6 summarizes the operating costs for the alternative process.

**Table 6. Operating Costs for the Alternative Process.**

<b>Operating Cost/Item</b>	<b>Cost (\$/Month)</b>
Testing	20,900
Lab analysis	72,576
Data analysis	30,000
<b>Total</b>	<b>123, 476</b>

Tables 7 and 8 summarize the capital and operating costs for the SEAttrace™ process and the alternative process.

**Table 7. Summary of Capital Costs.**

Capital Cost/ Item	Alternative	SEAttrace™
	Cost (\$)	Cost (\$)
Drilling	4,800	4,800
Expendables	8,112	8,112
Labor	8,500	8,500
Testing equipment	872	0
Mobilization	6,000	6,000
<b>Total</b>	<b>28,284</b>	<b>27,412</b>

**Table 8. Summary of Operating Costs.**

Operating Cost/Item	Alternative Process	SEAttrace™
	Cost (\$/Month)	Cost (\$/Month)
Equipment rental	0	2,000
Equipment/test setup	0	49,500
Testing	20,900	7,400
Lab analysis	72,576	0
Data analysis	30,000	6,600
<b>Total</b>	<b>123,476</b>	<b>65,500</b>

Capital costs for the alternative process are more than those of the SEAttrace™ system due to the sampling equipment required. For a larger barrier, the cost would be mitigated due to the reuse of the sampling bags.

The operating costs for the alternative process are more than double those of the SEAttrace™ system. The alternative process requires substantially more labor to accomplish the testing phase compared to the SEAttrace™ system. Laboratory analysis costs are considerably more compared to the SEAttrace™ analyzer system. Data analysis was a significant cost to the alternative process due to the programming, data input, and analysis required for each grid.

The net present value (NPV) was not calculated because the demonstration only lasted one month; however, a total project cost was calculated. Table 9 summarizes the total cost for each process.

**Table 9. Project Cost Comparison.**

<b>Alternative</b>	<b>SEAttrace™</b>
Cost (\$)	Cost (\$)
151,760	92,912

The SEAttrace™ system has operational and cost advantages over the alternative process: (1) samples can be obtained and analyzed within a matter of minutes, and (2) the data can be relayed from a remote site to the oversight engineer without much effort. The SEAttrace™ system has cost advantages over the alternative process due to the minimal amount of labor involved. However, maintenance and setup of the SEAttrace™ system could be difficult in harsh climates and remote sites.

The alternative process advantages include an on-site presence for any problems that may arise. Disadvantages of the alternative process include slow laboratory turnaround and increased costs. What takes the SEAttrace™ process minutes to do would take hours in sampling time and laboratory analysis for the alternative process, which in turn increases costs for the alternative process.

From a cost analysis standpoint, the SEAttrace™ system has significant cost savings over the alternative process. For the BNAS demonstration, the cost of the SEAttrace™ process was \$92,912, and the cost for the alternative process was \$151,760. Therefore, the SEAttrace™ process has a cost savings of \$58,848. The alternative process has a cost of \$40.40 per ft<sup>2</sup> of barrier compared to \$25.27 per ft<sup>2</sup> of barrier for the SEAttrace™ process. Therefore, the SEAttrace™ system has a cost savings of \$15.13 per ft<sup>2</sup> of barrier. Finally, the alternative process costs \$56.36 per sampling event compared to \$35.26 per sampling event for the SEAttrace™ system. Therefore, the SEAttrace™ system has a cost savings of \$21.10 per sampling event.

## SECTION 6 REGULATORY/POLICY ISSUES

### Regulatory Considerations

---

There are no regulatory issues currently involved with the SEAttrace™ System.

- The SF<sub>6</sub> tracer used in the monitoring and verification is a non-reactive and a non-hazardous gas.
- Except for drilling spoils, there is no generation of contaminated materials.
- Since the system is autonomous, no outside power is required.

### Safety Risks

---

- Worker safety risks are involved during the drilling of soil gas monitoring ports if contaminated spoils are excavated. (This risk is not an issue when using cone penetrometer or ResonantSonic™ technologies for port emplacements because no secondary waste is generated.)
- A slip, trip, and fall risk exists during the installation of tubing from monitoring ports to the monitoring system.

### Benefits and Community Reaction

---

- The entire system requires less than 40 ft<sup>2</sup> for operation and is relatively unobtrusive to the public. The monitoring system seated on a 10-foot long trailer is the only visible component of the SEAttrace™ System.
- The system quantifies leaks so that remedial actions (repairs) can be accomplished to minimize risk to the public.

## SECTION 7 LESSONS LEARNED

### **Implementation Considerations**

---

- During the installation phase, port locations and depths should be surveyed immediately after the installation of ports. These survey data are necessary in order to create a location file for the inversion code.

### **Technology Limitations and Needs for Future Development**

---

- The formulation of the Forward Model used in the inversion is inadequate to accurately determine leak size. It needs to be rewritten to remove the error function for situations where knowledge of leak size is required.
- The resolution of multiple leaks close to a single port could be improved.
- The system needs to be modified to allow for more frequent data downloads.

### **Technology Selection Considerations**

---

- Remote collection of data is dependent on the quality of service provided by the local phone carrier.

## APPENDIX A REFERENCES

- Betsill, J.D. and R.D. Gruebel. 1995. VAMOS - The Verification and Monitoring Options Study: Current Research Options for *In Situ* Monitoring and Verification of Contaminant Remediation and Containment within the Vadose Zone. Albuquerque, NM: Sandia National Laboratories, SAND95-1689.
- Dunn, S.D., W. Lowry, and V. Chipman. 1999. Subsurface Barrier Validation with the SEAtace™ System, Phase II Topical Report. Santa Fe, NM, Science and Engineering Associates, Inc.
- Environmental Protection Agency. 1998. Evaluation of Subsurface Engineered Barriers at Waste Sites. EPA 542-R-98-005.
- Falta, Ronald W.; Karsten Pruess; Stefen Finsterle; and Alfredo Battistelli, Eds. T2VOC. Sandia National Laboratories. Document No. 129847. Multimedia Environmental Technology, Inc.: Newport Beach, California, 1995.
- Heiser, J. H. 1994. Subsurface Barrier Verification Technologies. BNL-61127, Brookhaven National Laboratory.
- Rumer, Ralph R.; and James K. Mitchell, Eds. Assessment of Barrier Containment Technologies: A Comprehensive Treatment for Environmental Remediation Applications. International Containment Technology Workshop. Baltimore, Maryland. #PB96-180583. Springfield, VA: U.S. Dept. of Commerce, 1996.
- Walsh, Bob. 1995. Functional Design of Prototype Software Using Simulated Annealing to Estimate Underground Leak Size and Location. Report 95-091, Santa Fe, NM, Science and Engineering Associates, Inc.

### **Web Site Locations:**

- <http://www.seabase.com>
- <http://www.sandia.gov/eeselector/em/topics/monitor/monitor.html>
- <http://envnet.org/scfa/>